

# Creo



## SPECIFICATION SHEET

### TOPS

30 mm melamine faced chipboard (MFC) finished with 2 mm matching straight ABS impact resistant edges, easy to clean scratch-resistant anti-reflective melamine. MFC density 670/730 kgs per cubic meter.

Finish options:

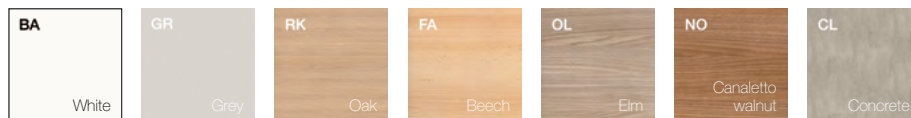

### METAL FRAMES

Legs are made of 40x40mm 1.5mm thick steel tube and are linked together by two upper 60x30mm 1.0mm steel tubular beams. Legs and beams are supplied epoxy powder painted. At the bottom footrests for those sitting at the table ends are welded to the legs and linked together by a long beam serving the same purpose as a footrest for those sitting at either side. Acting as structural elements footrests are made of epoxy powder painted 30x30mm 1.5mm steel tube coated with protective 0.8mm stainless steel.



Finish options:



Beams are always supplied in a silver finish.

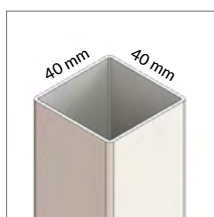

Leg made of 40x40mm 1.5mm steel tube.

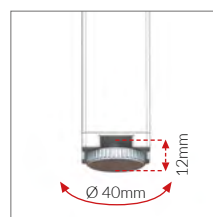

0-12mm adjustable levelling feet made of polyethylene, 40mm diameter.



## CREO TABLE



## SIZES

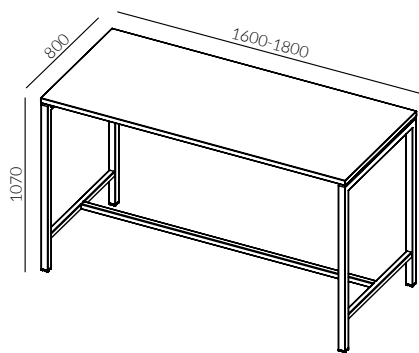

# SUSTAINABILITY & CERTIFICATES



## MATERIALS AND RECYCLABILITY

MFC panels used for Up&Up range tables are solely manufactured with 100% recycled wood and fully meet requisites of formaldehyde low emissions (E1 Quality Award Formaldehyde CATAS Certificate). Rasins used for panels and melamines are free of SVHC substances (to be found in the ECHA list updated as of 12/01/2017).



## CERTIFICATES

Quadrifoglio Group is always looking for quality and respect for the environment in all of its production processes. Today Quadrifoglio Group is UNI EN ISO 9001:2000, UNI EN ISO 14001:2004, BS OHSAS 18001:2007 as well as FSC™ certified and Ecological Panel.

COMPANY WITH  
MANAGEMENT SYSTEM  
CERTIFIED BY DNV GL  
= ISO 9001 =  
= ISO 14001 =  
= OHSAS 18001 =



## GREEN ENERGY

The Company had installed the photovoltaic system with 4.500 solar panels in a 7.350 m<sup>2</sup> surface that covers almost entirely the factory. The photovoltaic is able to produce 1Mw of a quiet green energy, that does not harm the environment and is waste-free. With his high production capacity the photovoltaic allows us to reduce emissions in the atmosphere of all those polluting substances and to those that contribute to the greenhouse effects. Consequently, such measures make us save every year 180 tonne of petrol oil, 440 tonne of CO<sub>2</sub>, 514kg of sulphur dioxide, 448 kg of nitrogen oxide and 23kg of dust.



## TRANSPORT

Detachable systems. Volumes that facilitate the optimization of space. Maximum reduction of energy consumption by transport.